

Assembly Instructions Series 14x-3

Box kits

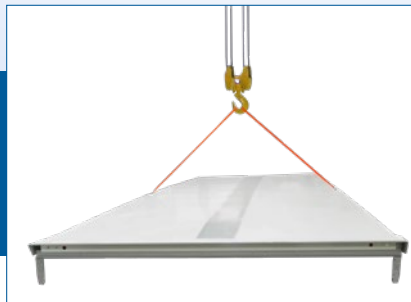

MA 14x3 .EN

Please be sure to read these instructions carefully and completely before commencing the installation.



Table of Contents

| | |
|--|----|
| 1. Safety and warning instructions | 2 |
| 1.1 Checking the scope of delivery | 2 |
| 1.2 Warning instructions | 2 |
| 1.3 Safety instructions | 3 |
| 1.4 Copyright | 3 |
| 2. Preparatory work / Human resources | 4 |
| 2.1 Human resources, preparations | 4 |
| 2.2 Required tools and equipment | 4 |
| 2.3 Tightening torques of the screws | 4 |
| 2.4 Preparations | 4 |
| 3. Assembly of the kit | 5 |
| 3.1 Assembling of the longitudinal supports (subframe) | 5 |
| 3.2 Assembling connection of floor and front wall | 5 |
| 3.3 Assembling of the side walls | 6 |
| 3.4 Placement and fastening of the roof | 7 |
| 3.5 Assembly of the frame, doors, top gate or sliding door | 8 |
| 3.6 Sealing and superstructure fastening in general | 9 |
| 3.7 Optional additional equipping | 9 |
| 4. Completion work | 10 |
| 5. Maintenance, Service | 11 |
| 6. Waste disposal of used boxes or component parts | 11 |
| 7. Scope of delivery | 12 |

1. Safety and warning instructions



This manual explains the assembly of kits 140-3 to 149-3. In order to generate a fault-free box body **absolutely adhere to the work instructions described here**, particularly the following warning notes, **the guarantee otherwise expires**. Coloured representations serve for illustration only.

If you have received a custom design, it is possible that some work steps are not explained here. Please also note that coloured representations are for illustration purposes only. **Get in touch with us immediately in case of uncertainties.**

1.1 Checking the scope of delivery

Check the shipment against the enclosed packing list for completeness. Notify any damage incurred during transit immediately to the delivering forwarding agent. In particular, the bottom chord of the walls and the floor profile must be undamaged. Damage can make the assembly difficult or impossible!

Please understand that we must reserve the right to make changes to the delivery in form, equipment and technology. Please find the general scope of delivery on page 12.

1.2 Warning instructions

AluTeam does not normally know how the kit is going to be used. **As the body builder, you must match the order and use of the kit to the requirements of your customer and the body guidelines of the vehicle manufacturers.** This also applies to the related materials and surface conditions. Damage caused by transported goods such as aggressive chemicals, do not represent a reason for complaint.

- Store the kit dry and clean (not outside).
- To ensure that no (splashed) water penetrates into the structure, the sealing cords in the panels must not show any signs of damage.
- Connect the components directly using the screws supplied. The assembly contact surfaces must be free from dirt.
- Never apply screws diagonally, they must not tilt. Consider the torques (2.3). Undershooting weakens the strength of the system, a clear overshooting can lead to damage to component parts!
- use the original screws and bolts, and use them only once! Third party or used screws or bolts endanger operational safety. Always use new AluTeam screws and bolts, even for repairs.

1.3 Safety instructions

Pay attention to your own safety and to that of your employees. Working with kits involves hazards. Therefore caution is always advised, in particular you should absolutely:

- ... **Wear safety gloves.** Wear **safety footwear**, as heavy parts can fall. Wear **hearing protection** as well as **safety goggles** when working with air screwdrivers, drills, grinding equipment, etc. Wear a **helmet** when working with or near a crane.
- ... Use a lifting beam when unloading or transporting of the packed kit with a crane. If using a forklift truck, push the transport rack completely onto the fork arms.
- ... Only place transportation frames onto flat surfaces, and secure them against inclination, tilting and toppling over.
- ... Always lift assemblies vertically, not at an angle! Never step under suspended loads! The suspension point/anchorage in the crane must always be above the assembly's centre of gravity!
- ... Remove all the packaging straps at the time of installation in the specified sequence. Please be sure to observe the instructions under 2.4!
- ... In case of utilisation of an assembly carriage, secure it against rolling away.
- ... Only lift the roof with a lifting beam or vacuum suction-unit! The mounting brackets (airline rails) are used for this purpose only as an assembly aid. Assembled boxes may not be lifted with them. **Risk of pulling out!**
- ... comply with the legal requirements such as StVZO, DGUV 70, BGV A1, BGG 915, DGUV 109-008. The Vehicle builder bears the responsibility.
- ... For cleaning and sealing work, make sure there is sufficient aeration and ventilation, and observe the processing specifications and the safety and disposal regulations of the adhesive/ sealant manufacturer. Request the safety sheet and the processing instructions from the manufacturer according to the cartridge print or from us.

1.4 Copyright

The copyright of these instructions belongs to AluTeam. They are only intended for the professional assembly company and its staff and, either in total or in parts, may not be:

- reproduced
- disseminated or
- disclosed in any other way.

Contraventions can have civil and criminal legal consequences!

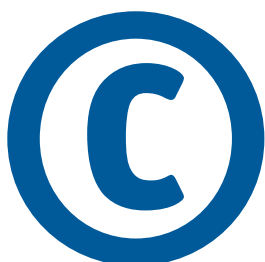
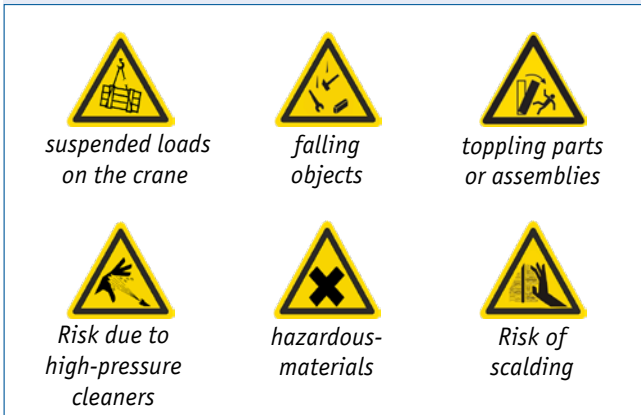

2. Preparatory work / Personnel requirements

AluTeam kits can be assembled in any well-equipped workshop. Carry out the following preparations beforehand.



2.1 Human resources, preparations

Two fitters with training as vehicle and body builders or equivalent training are required to assemble the body kits.

2.2 Required tools and equipment

- Tape measure (10 m)
- Precision compressed-air or cordless screwdriver (e.g. Fein Accutec ASM12-12)
- Screwdriver bit Tx 30 according to ISO 1173, hard and tough version, ¼" drive, min. 70 mm long (MH 170107), possibly + extension for screwdriver bits
- 4 Single-Stud Fittings (LoadLok 5018 o. allsafe JUNGFALK 7105/75018)
- 10-/13-/17-/19 open-jaw spanner or ratchet and small ratchet with matching nuts, possibly impact screwdriver and extension
- Air or manual mastic gun for 310 ml sealant cartridges
- Rivet gun for rivet diameter 5 mm
- 2x glue pliers for doors
- Crane with at least 1 tonne working load limit and vacuum lifting beam or lifting gear
- Hammer (500 gr.), Punch/Mandrel d = 3 mm and d = 4 mm
- 2 straight ladders or erection scaffolding
- HSS drill Ø 5.0 mm (shorter than the wall-thickness!)
- Carrying belts with hooks for lashing straps
- Painter's putty knife

2.3 Tightening torques of the screws

The settings for the screws must be checked by appropriate measuring equipment. The torques apply in case of dry screw thread. Adjust the following tightening torque in each case:

- | | |
|---|---------------|
| • Pan-head screw M 6 x 25 (MD100318) | 5 Nm ± 1 Nm |
| • Cap screw M 6 x 21 (MD100224) | 10 Nm ± 1 Nm |
| • Countersunk screw M 8 x 25 (MD100260) | 20 Nm ± 5 Nm |
| • Flat-head screw M 10 x 20 (MD100268) | 52 Nm ± 5 Nm |
| • frame screw M 12 x 45 (MD100307) | 125 Nm ± 5 Nm |
| • Substructure screw M 12 x 40 (MD100152) | 125 Nm ± 5 Nm |

2.4 Preparations

- The **ambient temperature** for components, as well as adhesives and sealants **must be at least 15°C**.
- **Secure the overall kit against tipping over, as well as its individual module assemblies.** These are stored on the pallet in the order they are required for construction. With extraction, first cut the red straps which secure a component in each case.
- As a rule, you carry out the Assembly on the chassis. Provide **sufficient free space** (at least 3 m) on both sides, as well as in front of and behind the vehicle and the required **Tools and Equipment** (2.2).
- In case of off-vehicle preassembly, place the floor of the kit e.g. on assembly dollies, pallets, trestles or polyurethane foam blocks. The floor must not sag, to ensure that the walls have full contact with the floor along their whole length. The corner pillars may not be closed off from below, as you may have to lay cables here later.

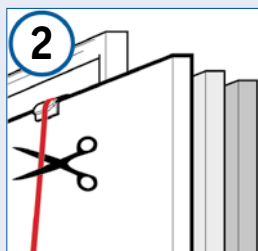
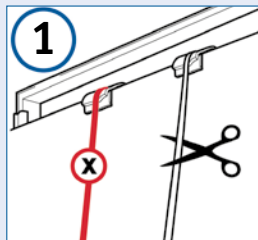

3. Assembling the kit

Adaptation work on the body, the floor assembly/substructure, e.g. drilling, **is the responsibility of the vehicle manufacturer.**

3.1 Assembling of the longitudinal supports (sub-structure)

In case of the kit BR14x-3, the sub-structure and the floor are component part of the kit and must be assembled professionally.

- Place both longitudinal supports with the vehicle-specific, pre-assembled brackets on the vehicle chassis. The V-Shaped section must point in the driver cab direction and the upper leg supports to outside. Align the beams according to the **diagonal dimension y** and **hole separation dimension x**. Be sure to comply with the dimensional dependencies $y_1 = y_2 \pm 4 \text{ mm}$ (**Diagonal dimensions schematic**).

The supports should rest on the longitudinal stringers flush with the outer edge of the vehicle frame and keep the same separation distance to the driver cab in front in each case.

- Fit the brackets to the side rails in accordance with the **attachment points on the chassis**. Only tighten them hand-tight.

Caution: Follow the body and conversion guidelines of the respective vehicle manufacturer. At least the two front fastenings between the longitudinal chassis beams and chassis frame must be spring-loaded. Otherwise, forces that occur during driving, e.g. in case of cornering, load changes or uneven loading, are transferred onto the body and can cause cracks in the body or subframe.

- Now measure again and check the hole separation dimension x and the diagonal dimension y . If required, re-adjust. If the dimensions ($X_1 = X_2$ and $y_1 = Y_2$) are consistent, first screw the front and rear brackets securely and after that the remaining brackets follow.

3.2 Assembling connection of floor and front wall

- To remove the floor assembly and position it on the side member, use carrying straps with hooks. Attach the hooks to the lashing brackets of the assembly and the straps to the crane.
- Cut the red strap and remove the assembly. Place it on the side member.

Danger: Crane-work involves hazards to life and limb. Never step under lifted loads! Always wear a helmet. Only lift loads vertically and not at an angle! The suspension in the crane must always be above the centre of gravity of the floor assembly!



- Align the floor centrally to the longitudinal chassis beams and the driver cab. There must be a separation distance of approx. 1.20 m to the front wall, so that you can attach the front wall later.

Danger: Toppling module assemblies endanger life and limb. Secure the floor against tilting and falling, where you fix it with four screws at the longitudinal supports.



- A foam strip protects the side floor profile. Now remove this strip.

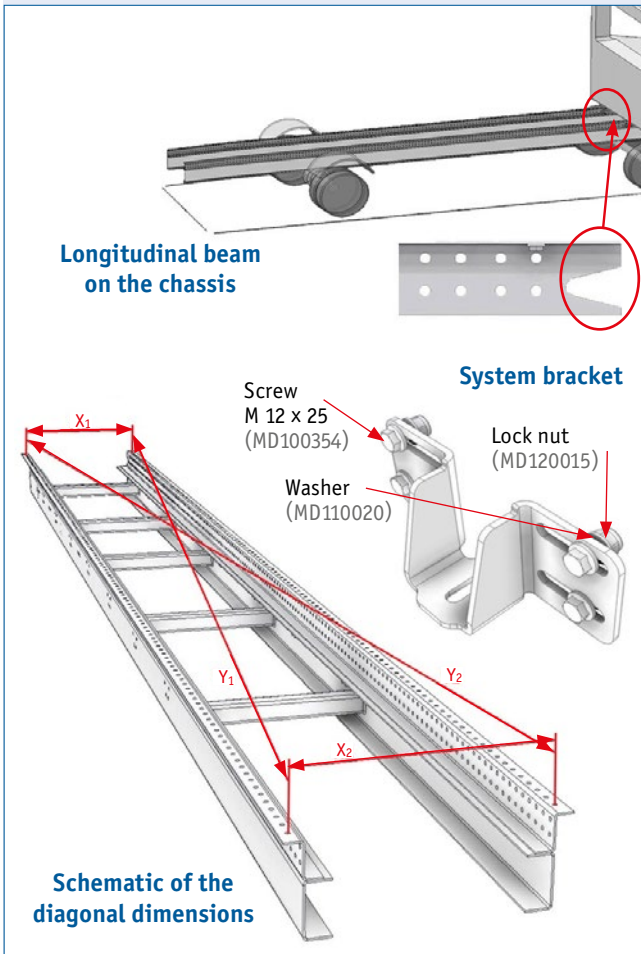

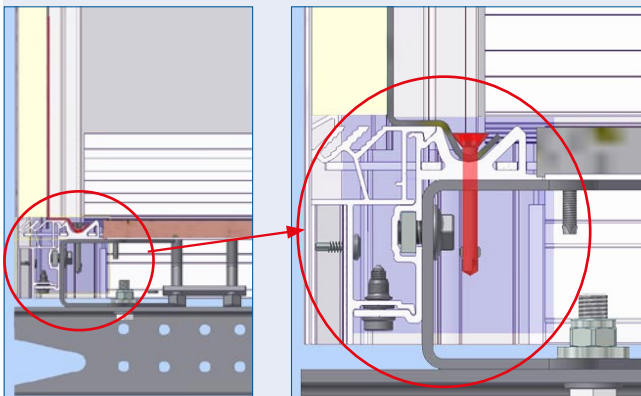
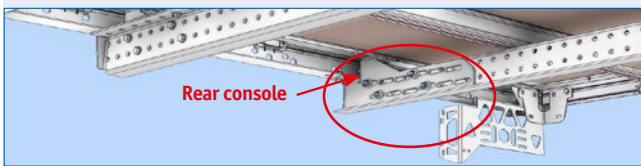
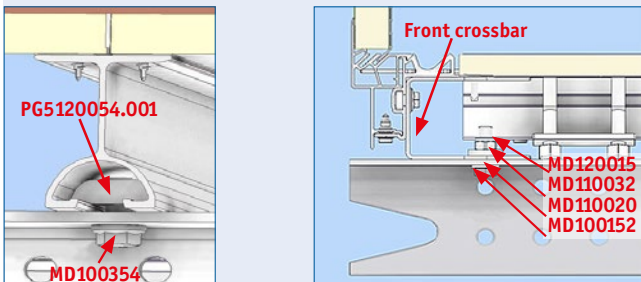

- Dismantle the side lashing brackets and set them into the free hole pattern in the outer frame of the floor assembly. Screw the lashing brackets tight from below.
-  Cut the red safety strap and remove the end wall from the transport unit using a crane and Lifting tackle or vacuum traverse.
- Place the wall with the bottom belt in the floor profile. The front wall and the floor must have a flush transition at the side. Optical check whether the lug is plugged in into the profile and whether there is still a Gap dimension.

Danger:  **Toppling module assemblies endanger life and limb.** Screw the right and left two screws (MD 100318) into the rivet-down nuts so that the front wall does not topple over. Check the side profile transition for flush finish.

- Then fix the front wall over the entire width with the delivered module assembly screws (MD 100318) and the gaskets (MD 110048). In difficult to access areas, use the small ratchet.
- Loosen the four floor screws fixed at the beginning and push floor and assembled front wall carefully to the driver cab up to reaching the parallel driver cab separation distance. In order to place the module assembly centrally and to prevent a side misalignment of the floor, one fitter per vehicle side must push.
- **Caution:** Protect the driver cab against damage with suitable means.
- Measure the separation distance of the exterior frame of the floor to the longitudinal supports in front and behind as well as to the left and right, and adjust the dimensions.
- In case of a **standard module assembly with steel longitudinal beams** insert the supplied threaded plates into the cross beams and screw the longitudinal supports with the floor using screws MD100354.
- Attach the rear brackets to the inside of the side members.
- Screw the front crossbar.
- Screw the plinth scuff plate already glued to the front wall with the supplied 6 x 60 Wing drilling screws (MD100272).

3.3 Assembling of the side walls

- Cut the red safety strap and lift the 1st side wall at the centre of gravity using a suitable lifting aid (crane with suitable harness, vacuum traverse or lifting plate). **Observe the safety instructions!**
Tip: It is best to fix the rear walls with glue pliers in order to prevent damage to the side wall.
- Ensure that no cables are present between connection points (danger of crushing the cables). They must hang down freely on the beginning and end of the wall.
- As with the front-side wall assembly, set the lower chord of the wall diagonally (approx. 10-15°C) into the floor profile.
- Check the flush transition and the gap dimensions again, especially in the side door area.



- The frame pillar should now fit flush with the frame cross beam and both are at right angle to each other below. Now tighten the screws used at the beginning securely with the appropriate torque.
- Fix the crossbar from the outside of the pillars with 4 M 12 x 45 mm screws each. Do not tighten the screws yet!
- Fix all walls inside the box from below using the assembly screws for the interior MD100224 starting to approx. $\frac{3}{4}$ of the box height. If necessary, use a punch as an assembly aid. a punch if necessary.

Caution: Unlike those for the outer area (MD100318), these screws have no gasket and are provided with a cylindrical head.



Proceed with the assembly of the 2nd side wall just like with the 1st side wall.

- Screw the walls together from below using the screws MD100318 incl. MD110048 sealing discs.

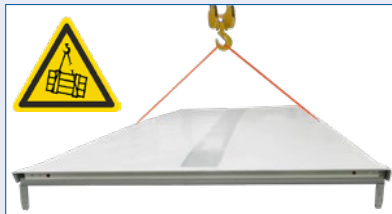

3.4 Placement and fastening of the roof

- Use the crane and lifting gear or vacuum lifting beam to remove the roof from the transport unit. Place it in a horizontal position and, if necessary (if you are working without a vacuum lifting beam), hook the single-stud fittings into the roof assembly rails. The fittings must be tight!

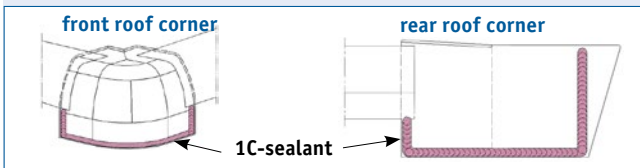

- Clean the preassembled roof corners (front and rear) on the inside using bond-activating cleaner and leave it for approx. 4 minutes to flash off and dry. Then apply a sealant on the inside sealing surfaces.
- The top frame gusset plates are pushed sideways into the frame cross members and fixed. Undo the fixing and turn the frame gusset plates until the pointed tip points downwards.

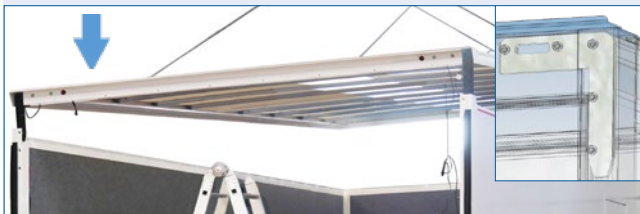

- Use the single-stud fittings or the vacuum lifting beam to lift the roof. Centre the roof, starting from the front, on the top rail of the front wall (bulkhead). The roof caps grip over the corner pillars. Align the roof with the wall sections.

Danger: Never stand under raised loads, lift the roof only if it is in a horizontal position, never suspended at an angle!

- Lower the roof slowly. Use a Painting spatula as an assembly aid if necessary. Centre the portal nodes pointing downwards centre them in the pillars. Fix them on each side with three countersunk screws M10 x 30 (MD100268).

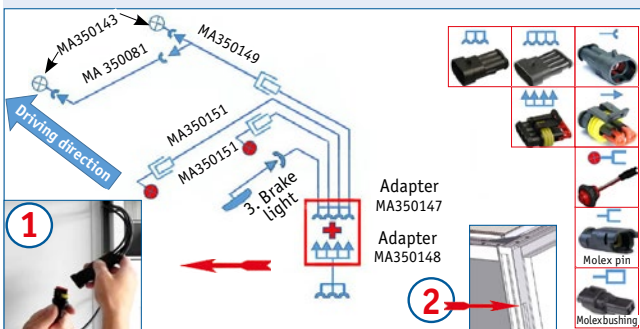

- **To wire the position lights,** simply 1. plug the connectors together and plugs together and 2. push the plug connection (right) downwards into the right-hand portal pillar downwards.

Caution: The cables and connectors must not be crushed.

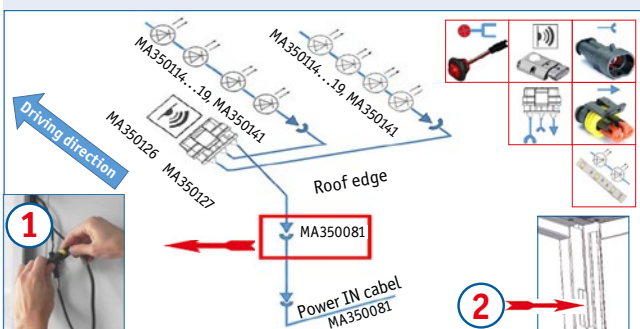

- For the **cabling of the navigation lights with motion detector (infrared sensor)** just connect 1. the plugs and slide 2. the plug connection downwards into the left-hand portal pillar.

Remark: The illustration indicates a cabling with LED strips on the right and left.

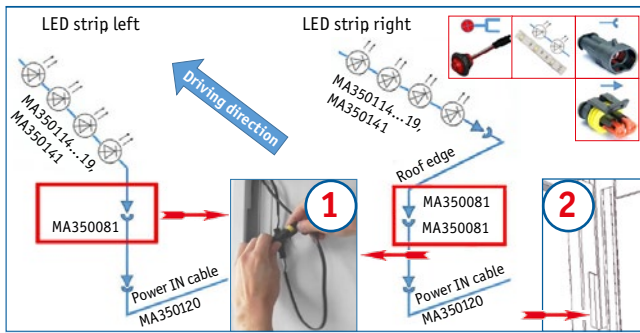

- For the **cabling of the LED strips without motion detectors**, just connect 1. the plugs and slide 2. the plug connection downward into the left frame pillar.

Remark: The illustration indicates a cabling with LED strips on the right and left.

- For the **cabling of the preassembled side marking lights (SML)**, just connect 1. the plug on the left side with the connection cable in the floor profile and 2. connect the plug on the right-hand side with this cable as well. Now insert the plug connections no. 1 and 2 into the floor profile on the front or on the side.

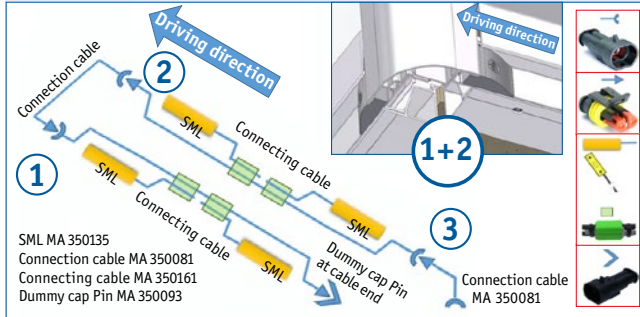

- Fix the roof on the front wall with 3 - 4 screws spread over the width of the front wall and tighten with the required torque.

- Measure the diagonals of the frame and correct them until they are identical.

- Tighten the screws of the frame gusset plates at the top to a torque of approx. 52 Nm, the screws of the bottom frame crossmember with approx. 125 Nm. The rear surface of the crossmember must form a flush plane with the rear surface of the pillars.

- Remove the single-stud fittings from the roof assembly rails. Screw the pillar connections from the bottom up, the front wall / roof connection crosswise and the side wall / roof connection from the front to the rear, each with the correct torque.

3.5 Assembly of the frame, doors, top gate or sliding door

- If a top tailgate is planned, fix it onto the roof flange using the holes provided in the hinge and assembly screws 6.3 x 22 mm (included in the top gate material).

Latch the gas springs of the gate onto the ball heads. In case of a frame pillar without integrated seal, use 2 brackets to secure the gate against lateral movement during operation **A**.

If the frame pillar has an integrated seal, use the assembly screws to secure the gate against lateral movement **B**.

- If the gate has butt hinges, the hinge brackets are fixed on the roof. Insert the hinge leaves here. Push in the hinge bolt and secure it.

- Frame doors are preassembled on the side walls. Close the doors and check the fit.

- If there are large deviations, an assembly error probably exists. In case of smaller differences, adjust the doors using the screws in the hinge leaves; in case of integral doors or doors with external rotary bars, adjust using the hitches on the frame crossmembers. Check the screws for tight fit!

- Roller-shutters and stainless steel frames are delivered unassembled. In the middle header you will find a link plate for the lifting gear. Remove the frame from the transport unit and push it onto the walls. Screw in the screws until the sections are pressed together. A Distance carrier stabilises the gantry columns. Dismantle this and insert the MD100260 screws into the slot.

For a steel or stainless steel gantry, slide the floor rebate from the gantry cross member under the base plate and screw it and fasten it over the pre-punched plate with the MD100300 screws. To install the roller shutter, proceed as described in the enclosed instructions. Pay attention to the contour lamp cable protruding from the pillars – **Risk of damage**.

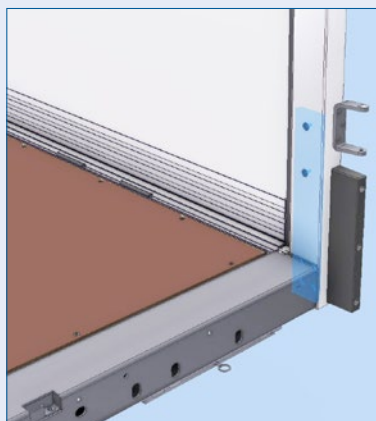

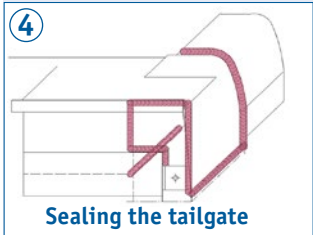

Sealing the tailgate

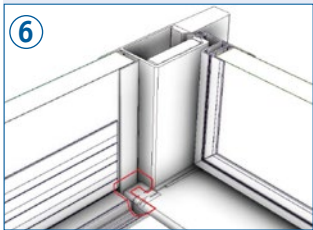

AluTeam recommends that boxes are generally directly on the chassis!

3.6 Sealing and superstructure fastening in general

- Remove the sealant that emerged inside at the roof corners.
- Clean the external sealing surfaces with bond-activating cleaner and leave for approx. 4 minutes to flash off and dry. ①
- Seal all round the front roof corners . ②
- Seal all round the rear roof corners as well as the roof edge - frame pillars connections, not only at the respective top end of the pillars, but also the top contact surfaces between the corner pillars and the frame crossmember with sealant. ③
- Seal kits with top tailgate above the tail-lift as described in the drawing. ④
- Seal the floor at the front and rear corners. ⑤
- For kits with roller shutter door or steel or stainless steel portal, the portal cross member must be sealed across the entire width to the roof; for roller shutter door portal, the transition from the cross member to the floor panel must also be sealed. ⑥

Caution: Smooth off all sealing using only polishing agent or water without soap additives. ⑦

General superstructure mounting

We recommend attaching the substructure directly to the chassis. The substructure or chassis must be levelled and torsion-free on a flat surface.

Follow the body and conversion guidelines of the respective vehicle manufacturer, in particular the positioning and type of subframe connection, flexible or stiff under shear.

Forces acting on the rear bumper guard must be able to be safely transferred into the auxiliary frame or chassis. The frame and the body are not designed to absorb forces caused by docking operations!

As a minimum, the two front fastenings between the longitudinal chassis beams and chassis frame must be spring-loaded.

In general, adjustment work such as drilling must be carried out by the body builder and does not constitute grounds for complaint.

Use the crane and lifting gear to position the finished box body on the auxiliary frame or chassis. Never lift the assembled box body by the roof eyebolts. **Risk of pulling out!**

Caution: The condensation drain holes of the bottom rail sections of series 140-2 and series 142-2 as well as the water drain holes of the side gates and side doors must remain clear even after they have been mounted on an subframe!

3.7 Optional supplementary equipment

Unlike the model range 14x-2, we offer further additional options, such as the preassembled tail pull-out ladder or the door holder. The options, which are described in the following, must still be attached however.

- In case of a tail lift, you may need to refit the rear lights. With the **rear light brackets** (right-hand KM390010360000R; left-hand KM390010360000L), the lights can be mounted horizontally or vertically. The brackets are pre-punched for the rear lights of usual vehicles.

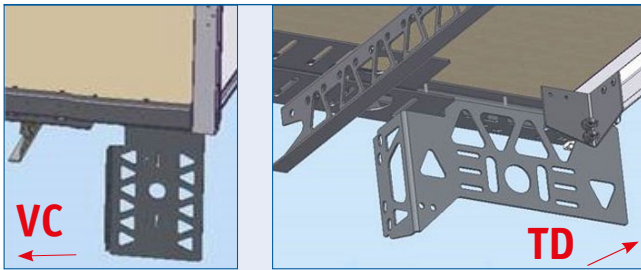

- Fix the bracket with the hexagon socket M 10 x 30 (MD100227) and the washers (MD110002) to the frame cross beam. The folded legs must point backwards, against the direction of travel (TD). A bevel serves for the screwed connection with the frame cross beam. The second bevel points toward the centre of the vehicle (VC).

Screw the reinforcing bracket KS320190 to the console using the hexagon socket screw MD100227, the washer MD110002 and the safety nut MD120002. The reinforcing bracket is attached to the floor profile using the MD100360 screw and the threaded plate (MA430255).

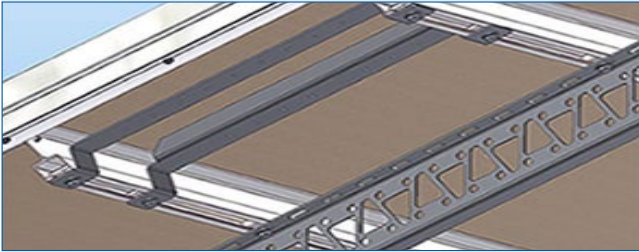

- With the **fender bracket** option KS 320185, the brackets are pre-assembled to the sub-structure with cross beams. Screw off the brackets. The threaded inserts remain in the cross beams. Use fenders with flat assembly surfaces (not included in the scope of delivery). Place the two parts of the brackets symmetrically in longitudinal and transverse direction to each other on the assembly surface of the fenders. The bevel must point upward.

Use the holes in the brackets as a drill template and drill the fenders. Screw the components together with the screws MD 100265, washers MD 110001 & nuts MD 120001.

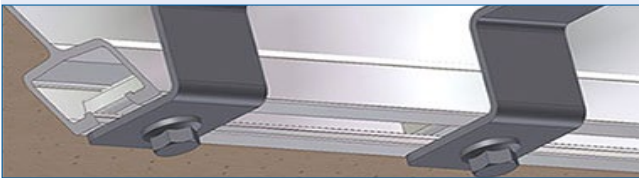

Secure the fender bracket with the threaded inserts MD 100354 and the screws removed at the beginning to the cross beams. Align the fenders centrally over the running-contact surface of the wheel. Check if the tyre can move freely and correct as appropriate, then tighten the screws with the appropriate torque.

4. Finishing Work

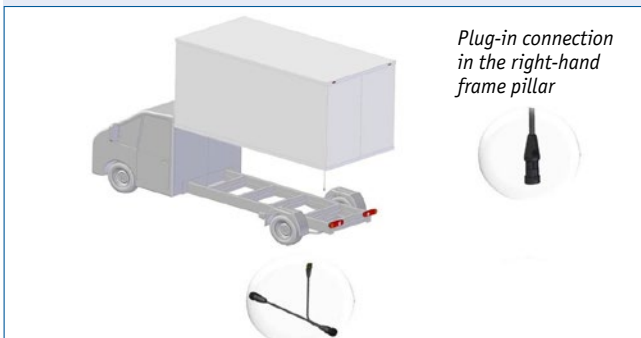

Plug-in connection in the right-hand frame pillar

Supplied connection cable

Mercedes: Atego, Antos, Actros - MA350155 & MA350083

DAF, MAN TGM, TGL, TGE, sowie VW Crafter und Scania: MA350158

Iveco Eurocargo: MA350190 / Iveco Daily: MA350159

MB Sprinter, Opel Movano, Citroen Jumper, Peugeot Boxer: MA350158

Mitsubishi Fuso Canter, Fiat Ducato, Renault Master: MA350158

Ford Transit: MA350168

- Close the side screw holes on the rear pillar with the supplied plugs MA150001.
- Then, depending on the body features, pull the connect cable for the side lights out of the frame pillar and connect it to the connection cable of the respective vehicle manufacturer.

- Where appropriate, screw the hand grip to the inner right portion of the frame pillar.

- You can generally paint over our coil coating and powder-coated parts with traditional wet paints. For a secure adhesion, get in touch with the paint supplier especially concerning the primer.

Untreated and zinc-coated profiles are to be treated with a suitable primer before painting. The temperature in the painting cubicle may not exceed 60°C.

- Pay attention in particular to the corrosion protection in case of subsequently attached component parts or modified AluTeam components. In particular, you must absolutely exclude contact corrosion through different materials. Otherwise the guarantee on the painting, coating and bond is voided.

- Check the roof corners, doors and the lighting for tightness e.g. by a water test for structures, following EN 283.

For this, direct a water jet from a 1/2" nozzle (Ø 12.5 mm inner diameter) at a pressure of over 1 bar onto the external sealed joints. Hold the nozzle at a distance of approx. 1.5 m from the structure. After the test, no water should have penetrated into the structure.

- The assembled box body must not yet be loaded. Note that the final strength of the sealant (at 20 °C) is not reached until after 24 hours.

Caution: You may only clean the structure with a steam cleaner after 6 weeks. Please absolutely consider the corresponding explanations under „4. Maintenance“.

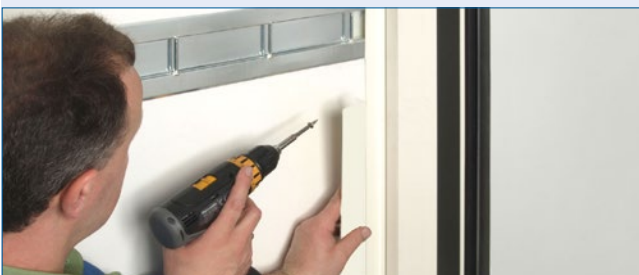

Attention: Paints, solvents and dust are harmful to health. Protect yourself!

5. Maintenance, Service



For the maintenance of the structure, check all screws are tight (also in case of sliding doors!) at regular intervals but at least once a year. Also check the prescribed torque in the process.

- Locks and closing cylinders are maintenance parts. They must be kept serviceable with lubricants when necessary. Locks seized due to poor maintenance are not a reason for complaint.
- When cleaning the body with a steam jet cleaner (after 6 weeks at the earliest) maintain a minimum nozzle distance of 300 mm. The maximum allowable water temperature of the cleaner is 60°C, the working pressure is 100 bar, and the pH-value is 4 - 10. Rinse immediately with clean water. Remove flash rust on stainless steel (including the frame) using common household stainless steel cleaners.
- Treat all seals with a rubber care agent after every cleaning.

In case of questions related to the assembly, our **Customer Service** will be glad to help you: **Tel: +49 (0)521-41 73 11-30,**
Email: m.wismueller@aluteam.de

If you require **spare parts**, please contact your responsible sales representative or call us at: **+49 (0)521 - 41 73 11 - 10**

Please send e-mails to: info@aluteam.de

6. Waste disposal of used boxes or component parts



According to the Industrial Waste Ordinance - GewAbfV (or the regulations valid in your country), discarded components must be recycled. Sort the respective materials and then proceed as follows:









- You can remove the **metallic layers** from the foam core and have them recycled together with aluminium via the scrap trade. The same applies to the steel and/or stainless steel components of the frames.
- A **PUR foam core** can be burned in thermal waste treatment systems without contaminating the environment. **Plywood**, like particleboards, can be burned in wood-fired furnaces with at least 50 kW nominal heat output. They are subject to stricter carbon monoxide limits than solid wood. These values are mostly only achieved by automatically loaded plants. Odour nuisance due to the ammonium additives in the binders must be avoided.
- **GRP** must be processed by a recycling/recovery company, and is used as a substitute fuel. For energy recovery in a cement works, the EWC code is 070213 (waste plastic).
- For information on disposing of the foam in the area of the floor, contact the trade association for extruded polystyrene foam (In Germany: Fachvereinigung Polystyrol-Extruderschäumstoff (FPX), Odenwaldring 68, 64380 Rossdorf (<https://xps-spezialdaemmstoff.de/wp-content/uploads/OPS-MIT-cogeneration-Transmittent-1.pdf>))
- **Hardened adhesives and sealants** are disposed of as residual waste (black bin). **Residual quantities of solvents**, as hazardous waste, must be handed into the respective disposal company or collection point. The technical data sheets can be requested from the individual manufacturers.

7. Kit Contents



Please understand that we must reserve the right to make changes to the scope of delivery with regard to form, equipment and technology.

Included in the scope of delivery of a kit BR13x-3:

- Floor assembly incl. side members right and left
 - Front wall module assembly
 - Module assembly screws (pan head) M6 x 25 VA, MD100318 incl. sealing washer MD110048 
 - Subframe screw M12 x 25, MD100354 
 - screw thread inserts PG51054.001 for the aluminium cross members
 - Subframe screw M12 x 40 MD100152, washers MD110020, washers MD120032 und M12 hexagon nuts MD120015 for fastening the Front carrier
 - Konsoles for connecting the box to the chassis
 - 2 x side wall assemblies, right and left, including rear pillars and, depending on the features, with attached side doors
 - *for side doors optional rain moulding incl. fixing material*
 - Roof assembly with integrated frame crossmember, including frame gusset plate as well as preassembled roof corners
 - **optional** stainless steel -or steel rear portal, e.g. in kits with roller shutter frame
 - **For tail lift kits:** *tail top gate with gas pressure spring and mounting screws MD 100058, and material to fix the flaps on the sides (depending on the type of flap)* 
 - Assembly screw (Cylinder head) M 6 x 21 Tx30 self-locking, AluTeam Article No.: MD100224 
 - Countersunk screw M 10 x 30 galvanised, AluTeam Article No.: MD 10026 – Aluminium pillar connection to roof 
 - Screws M 12 x 45, MD 100307 for connection the aluminium pillars to the bottom frame crossmember 
 - Plugs for bolting holes in the frame pillars 
 - Handle MA200152 with self-tapping fastening screws MD100202
 - 1C-sealant and adhesive, bond-activating cleaner 
 - If necessary, a connection cable for truck chassis, as in the order (see circuit diagram)
 - **optional** rear-light bracket with reinforcement bracket KS320190, hexagon socket screws M10x30 MD100227, lock nuts MD120002 and washers MD110002 as well as screws MD100360 and the threaded plate MA430255
 - **optional** mudguard bracket KS320185 pre-assembled incl. threaded inserts PG51054.001 with matching screws MD100354, screws MD100265, washers MD110001, nuts MD120001
 - Access ladder MA350134 pre-assembled in the rear or under the side door, if required
 - Door retainer MA200377 pre-assembled for rear or side doors, if required
 - Paper tissues
 - Stick-on label with structure number
 - *Optional sticker "Tested load restraint"*
- Attention:** *The stick-on label is only valid with a certificate issued by AluTeam!*
- Assembly instructions