

# Swap body bolster rigid 335 x 85

- > steel raw
- > for C745 / C782
- > 2 twist locks on each side (inner parts 410.075.620)
- > **with two guide rollers**, incl. empty storage
- > bolster 85 mm high
- > weight 100 kg

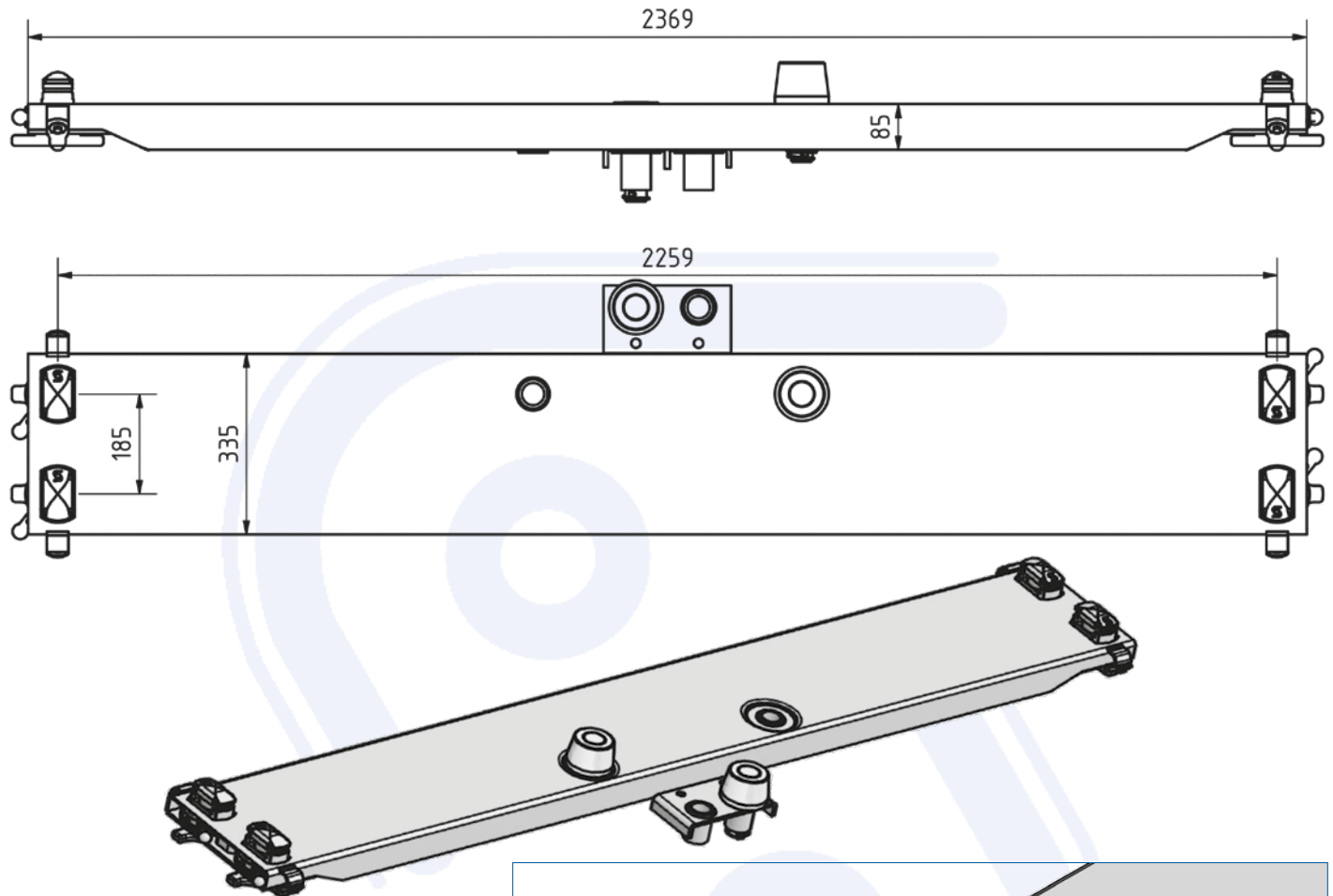

Art.-No. 410.078.725



Pos.	Einzelteil	Art.-Nr.
1	Bolster	410.078.705
2	Locking pin	906.000.276
3	Locking pin guide	906.000.273
4	Outer guide	906.000.274
5	Locking nut	906.000.275
6	Security ring	905.000.187
7	Holder f. security latch	905.159.006
8	Security latch	905.159.005
9	Washer	906.036.005
10	Screw	DIN 933 - M8x16
11	Screw	020.008.016
12	Self-locking nut	DIN 985 - M16
13	Holder f. guide roller	640.003.001
14	Guide roller /85	640.003.110
15	Folding pin 12x55	640.003.112

